



CHRISTIE ENGINEERING



POWERED by
HONDA



The Original Petrol Post Driver

Manufactured in Australia



- COMMERCIAL GRADE TOOL
- 3 YEAR WARRANTY
- LIGHTWEIGHT AND PORTABLE
- UP TO 500 POSTS PER LITRE



www.christieengineering.com.au

@christieengineering

Petrol Post Driver Range

CHPD52

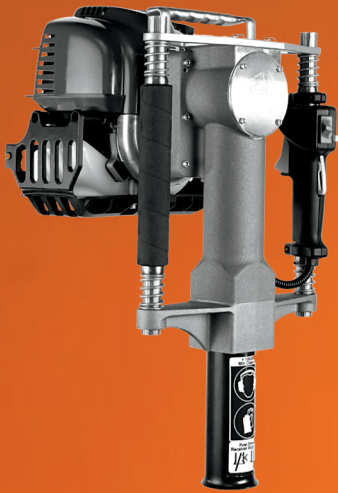

CHPD78



CHPD107



Post Types	Features	Motor
<ul style="list-style-type: none"> Standard Star / Y Pickets Grounding Rods Up to 52mm OD Round posts 	<ul style="list-style-type: none"> 1720 BPM Spring Dampened Hand Grips Protective sump guard 13.5kg 	<ul style="list-style-type: none"> Honda 4-stroke GX35 1 Kw (1.3hp) 91 - 95 octane unleaded Petrol Consumption; 0.71 L/h @ 7,000 rpm 360-degrees inclinable during operation
<ul style="list-style-type: none"> Standard & Maxi Star / Y Pickets 50 & 65nb pipe for strainers / road sign posts Up to 76mm OD Round Posts 	<ul style="list-style-type: none"> 1720 BPM Spring Dampened Hand Grips Protective sump guard 15.6kg Includes 78-52mm push-in reducing bush 	<ul style="list-style-type: none"> Honda 4-stroke GX35 1 Kw (1.3hp) 91 - 95 Octane Unleaded Petrol Consumption; 0.71 L/h @ 7,000 rpm 360-degrees inclinable during operation
<ul style="list-style-type: none"> Standard & Maxi Star / Y Pickets 50 - 90nb pipe for strainer posts / end stays / stockyard posts Up to 105mm OD Round Posts 	<ul style="list-style-type: none"> 1780 BPM Spring Dampened Hand Grips Protective sump guard 17.5kg Includes 107-78mm, 107-52mm reducing bushes & Multi Size NB Pipe Anvils (50-90Nb) 	<ul style="list-style-type: none"> Honda 4-stroke GX50 1.5 Kw (2.0hp) 91 - 95 Octane Unleaded Petrol Consumption; 0.7L/h @ 7,000 rpm 360-degrees inclinable during operation

Post Driver Cases Available

